

Aluminum valves with (left to right): Electro Pneumatic, Manual, and Motor Actuators. Stainless Steel valves also available.

ANSI, ISO, JIS, or Special Flanges

These Vacuum Research 5 minute rebuild valves are available with virtually any flange or combination of flanges at no extra charge. Combinations of ISO on one flange and ANSI on the other are easily accommodated. Even different sizes such as 4 inch on one flange and 6 inch on the other.

Insertable "Flangeless" Valves

It is sometimes helpful to keep the flange-to-flange dimension ("A" dimension on the dimensions pages) as short as possible. In such cases your valves can be provided with no port flanges at all and with either O-Ring grooves machined into the valve body or with a precision machined surface on the body to seal against the O-rings on your pump or chamber. Contact the factory for prices.

Aluminum or Stainless Steel

Vacuum Research Bonnet Style valves are available in stainless steel or 6061 aluminum. Smooth surface finish gives low outgassing and fast pump down.

High Conductance

In addition to the oversize ports used in the LPWA Series for the last 40 years, we now offer the X-LPWA Series where a 4 inch valve has a 6 inch port, an 8 inch valve has a 10 inch port, etc. Conductance values are shown on page 39.

Fail Safe

All Vacuum Research Bonnet Style Valves can be installed for fast close on power failure and air operated valves can be manually positioned without air or electricity.

Long Life

More than 250,000 cycles for aluminum valves. That's one cycle every 2 minutes, 24 hours/day for a year.

SolidWorks *.STEP Files

Contact us to obtain SolidWorks 3D *.STEP format modeling files that plug formatted VRC valve 3-D models into your computer-aided design projects.



Less Outgassing Than Stainless Steel

Dozens of papers show the 6000 Series aluminum used in VRC valves outgasses up to 2 orders of magnitude less than 300 Series stainless steel and of course no hydrogen. A bibliography of 70 peer reviewed papers about out-gassing compiled by Dr. M. Wong at Fermi Labs can be found at http://home.fnal.gov/~ml-wong/outgas_rev.htm. See page 40 for more information

Vacuum & Pressure

Vacuum Research valves stay sealed with vacuum or atmosphere on either side.

Satisfaction Guaranteed

Vacuum Research has been building high vacuum valves for almost 50 years and has earned a reputation for world class product quality and customer service. If you are not satisfied with our valve just send it back.

No Leaks

All Vacuum Research valves have total leak rates of less than 5 X 10⁻¹⁰ std cc/sec. By total leak we mean that each completed valve is tested in a He filled bag.

RoHS Compliant

All Valves are (RoHS) 2015/863/EU Compliant and carry the mark.

Electric Motor, Air or Manual Actuators

All Vacuum Research gate valves are available with 3 types of actuators. Manual actuators are the least expensive. Electro-pneumatic actuators use 70 psi (4.9 kg/cm) compressed air and include the solenoid (specify the solenoid voltage that is most convenient for you). Electric motor actuators use high torque servo motors and operate from 115V or 230V, 1Ø 50 or 60 Hz. CE Mark included.

Roughing and Gauge Ports

There are six locations for optional gauge and roughing ports described on page 43.

Position Indicators, Limit Switches

Visual indication of valve position is included on all valves. Limit switches for remote indication are available and are described on the Optional Features pages in the Accessories & Parts section.

Complete Rebuild in 5 Minutes.

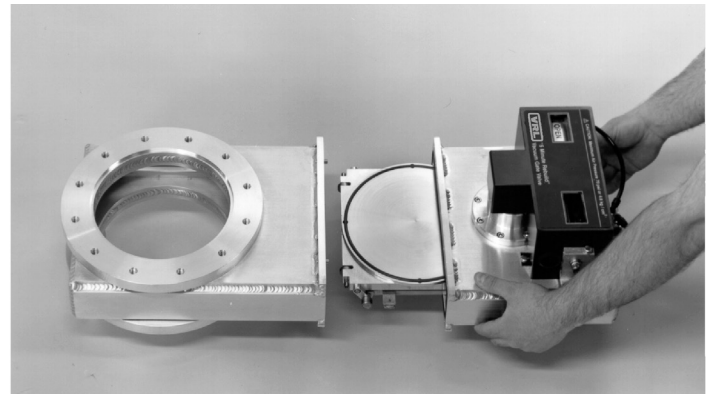

With no special tools or training you can replace every moving part in your Vacuum Research Bonnet Style Valve in 5 minutes. (Our best guys can do it in less time, but they practice.)

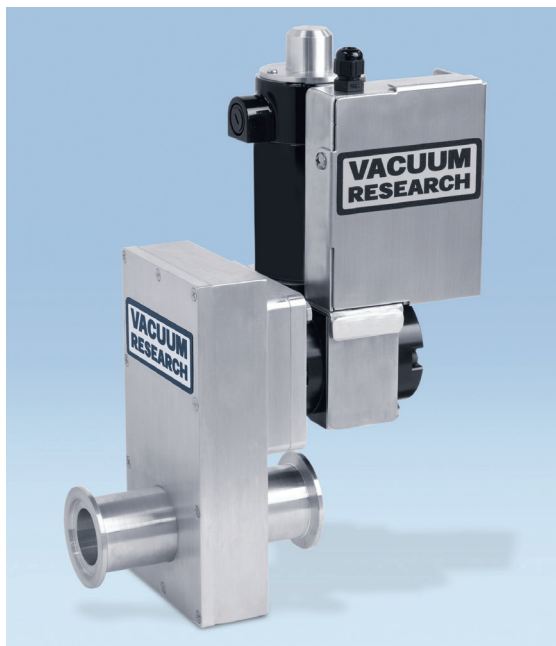

Throttemaster™ Gate Valve and Motor Positioner Unit. Aluminum has less outgassing than stainless steel. Up to 2 orders of magnitude less, see references on page 39.

- Aluminum or Stainless Steel Valves
- Seals Up To 3 Atmospheres Differential
- Vacuum or Atmosphere on Either Side
- ANSI Sizes From 2 Inch to 24 Inch
- ISO Flanges From 63 to 630 mm
- Manual or Closed Loop Operation
- All Valves (RoHS) 2015/863/EU Compliant

The Vacuum Research Throttemaster™ valve with positioner can be used in either of two control schemes. As a 3 position valve for upstream pressure control with an MFC, or for downstream pressure control with modulating gate position. For 3 position control the basic Throttemaster™ consists of two components: an aluminum or stainless steel gate valve and a positioner/indicator to drive the fast response servo motor. This is all you need to operate the Throttemaster™ as a 3 position valve in systems where the mass flow controller is controlling the pressure.

The Throttemaster™ can also be used for downstream pressure control where the gas flow to the chamber is held constant and the Throttemaster™ gate is moved to control conductance of the pumping system. This requires the use of a PID pressure controller to provide a signal to the valve positioner and a vacuum gauge with a 0 to 10 vdc signal to the PID controller. These may be purchased from Vacuum Research along with your Throttemaster™ Valve and positioner or you may be able to use your present gauge and controller.

Throttemaster™ Dimensions

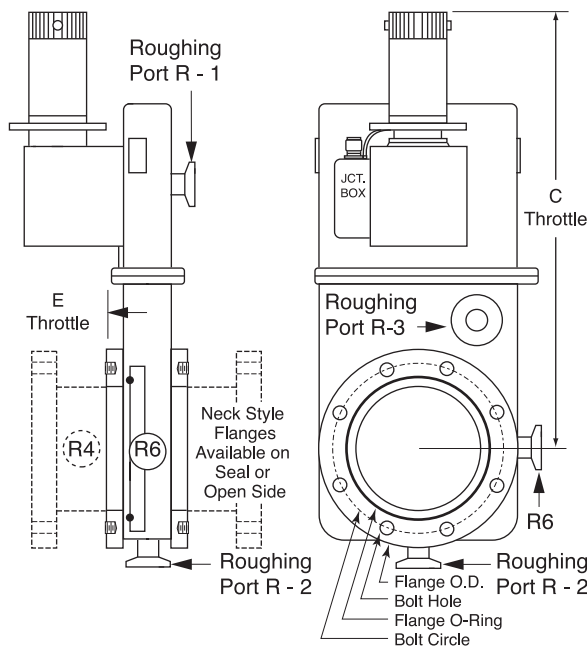

Port dimensions, bolt patterns, and other dimensions are shown on pages 6 and 7 for ANSI and page 13 for ISO valves. A few dimensions unique to the Throttemaster™ servo actuator are listed here.

ANSI Flange Port Diameter	2 & 3 in. 4 in. Port	4 in. 6 in. Port	6 in. 8 in. Port	4 in. 6 in. Port	8 in. 10 in. Port	12 in. 12 in. Port
C Throttle	15.90 in.	19.17 in.	22.00 in.	22.00 in.	20.67 in.	22.74 in.
E Throttle	4.34 in.	4.15 in.	4.03 in.	4.03 in.	3.90 in.	3.90 in.

ISO Port Size	63 & 80 mm	100 mm	160 mm	200 mm	250 mm	320 mm
C Throttle	403 mm	403 mm	487 mm	561 mm	525 mm	577 mm
E Throttle	110 mm	110 mm	105 mm	102 mm	99 mm	99 mm

P.I.D. Closed Loop Downstream Pressure Control

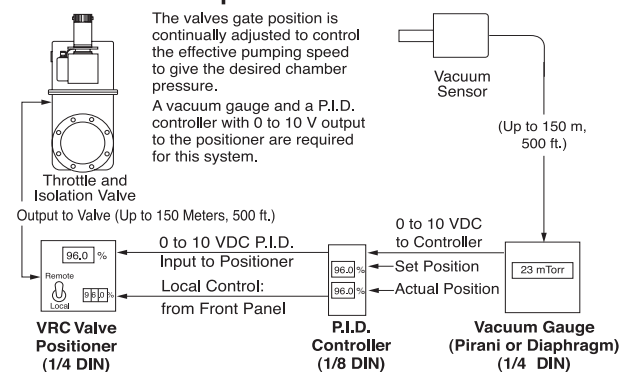

3 Position or Upstream Control

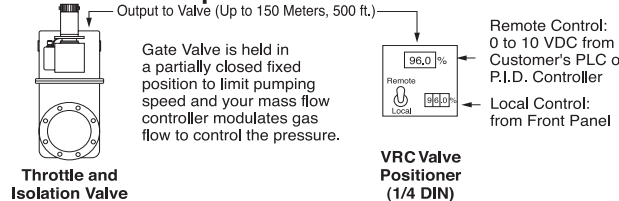

Stainless Steel Throttlemaster™ Valve System with Positioner			
Port Size	Flange Size	Model	Price
25 mm	NW-25	STM-25	\$8,394
40 mm	NW-40	STM-40	\$8,686
50 mm	NW-50	STM-50	\$8,978
63 mm	ISO-f 63 mm	STM-63	\$9,451
80 mm	ISO-f 80 mm	STM-80	\$10,403
100 mm	ISO-f 100 mm	STM-100	\$10,145
160 mm	ISO-f 160 mm	STM-160	\$11,277
200 mm	ISO-f 200 mm	STM-200	\$14,962
250 mm	ISO-f 250 mm	STM-250	\$21,530
320 mm	ISO-f 320 mm	STM-320	\$22,550
400 mm	ISO-f 400 mm	STM-400	Contact Factory
500 mm	ISO-f 500 mm	STM-500	Contact Factory
3.375 in.	ANSI 2 in.	STM-2	\$10,057
3.375 in.	ANSI 3 in.	STM-3	\$10,400
5.375 in.	ANSI 4 in.	STM-4	\$11,458
7.125 in.	ANSI 6 in.	STM-6	\$13,131
8 in.	ANSI 8 in.	STM-8	\$15,145
11.625 in.	ANSI 10 in.	STM-10	\$21,748
12 in.	ANSI 12 in.	STM-12	\$23,922
16 in.	ANSI 16 in.	STM-16	Contact Factory
20 in.	ANSI 20 in.	STM-20	Contact Factory

Aluminum Throttlemaster™ Valve System With Positioner			
Port Size	Flange Size	Model	Price
25 mm	NW-25	ATM-25	\$4,546
40 mm	NW-40	ATM-40	\$4,599
50 mm	NW-50	ATM-50	\$4,663
63 mm	ISO-f 63 mm	ATM-63	\$4,773
80 mm	ISO-f 80 mm	ATM-80	\$5,346
100 mm	ISO-f 100 mm	ATM-100	\$5,497
160 mm	ISO-f 160 mm	ATM-160	\$5,789
200 mm	ISO-f 200 mm	ATM-200	\$7,295
250 mm	ISO-f 250 mm	ATM-250	\$10,399
320 mm	ISO-f 320 mm	ATM-320	\$12,283
400 mm	ISO-f 400 mm	ATM-400	Contact
500 mm	ISO-f 500 mm	ATM-500	Contact
620 mm.	ISO-f 630 mm	ATM-630	\$Contact
3.625 in.	ANSI 2 in.	ATM-2	\$4,773
4 in.	ANSI 3 in.	ATM-3	\$5,346
6 in.	ANSI 4 in.	ATM-4	\$5,537
8 in.	ANSI 6 in.	ATM-6	\$6,671
10 in.	ANSI 8 in.	ATM-8	\$6,879
12 in.	ANSI 10 in.	ATM-10	\$10,399
12 in.	ANSI 12 in.	ATM-12	\$12,273
16 in.	ANSI 16 in.	ATM-16	Contact
20 in.	ANSI 20 in.	ATM-20	Contact
24 in.	ANSI 24 in.	ATM-24	Contact

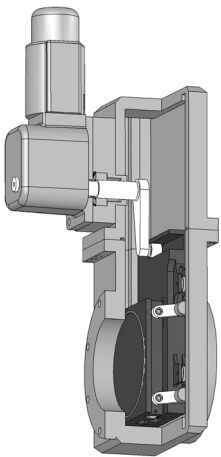

Throttlemaster™ Fully Closed
Note that crank arm is vertical and links are near horizontal

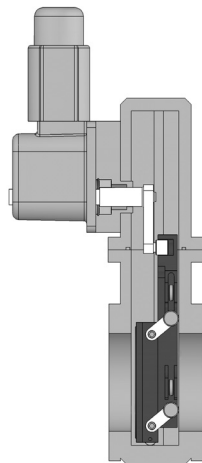

Throttlemaster™ 90% Closed
Note that gate has moved only .036 inch (0.9m) from the seal surface

Max Conductance Precision Where it's Most Important

The only Throttle Valve in the world that uses back-to-back sine law relationships to provide maximum conductance precision where you need it most; between 90% to 100% closed!

Why is the Throttlemaster™ conductance precision so good between 90% and 100% closed? There are two design features that allow both leak tight shut off and high resolution in the critical 90% to 100% closed range. The first of these is innovative mechanical design of our actuator, and the second is our high resolution feedback system.

The 180° arc of our actuator arm is double that of butterfly valves. More importantly, the critical 90% to 100% closed position is at bottom dead center where the motion per degree of rotation becomes zero. As this is happening, the gate links are approaching their full extension, which further enhances the resolution of the crank rotation and feed back sensor.

The Vacuum Research feedback element is directly coupled to the motor shaft, and provides stepless resolution of the valve position. The motor itself is a high torque servo that can repeatedly position the gate within a few thousandths of an inch and also lock the gate closed with a full atmosphere differential.

Optional Features

The valves used in the Vacuum Research Throttlemaster™ are the same as the standard open/close valves discussed on pages 4 to 7 of this cata-log. The difference is that the Throttlemaster™ gate position is precisely controlled by the servo motor actuator and the valve positioner to full open, full close, or anywhere in between. A Throttlemaster™ valve can be equipped with roughing and gauge ports and most of the options listed in optional features section.

Valve Motor Voltage

The standard valve motor is 115V, 60 Hz approximately 300 w for 220-240V, 50 Hz. Add suffix 220/50 to P/N.....No extra charge.

Viton® and Kalrez® O-Rings

Throttlemaster™ valves are shipped with Buna-N O-Rings except for the gate seal which is Viton®. For valves with all Viton® or Kalrez® see page 5 for prices on these special O-Rings.

Spare Valve Positioner

Remote mini Valve Positioner: P/N X801403.....\$1,566

Hand Held Controls:.....\$592

Cable Between Valve and Positioner

A 25 ft. (7m) cable is included with each Throttlemaster™ and cables up to 500 ft. (150 m) are available. If more than 25 ft. is required add the length as a suffix to the valve model number and add:\$5/ft.

Throttlemaster™ is a trademark of Vacuum Research.



Vacuum Research valves are available with dozens of options to allow you to select exactly the features you need for your vacuum system. The model number system illustrated below will accurately describe most valves, but if you have any questions about the best way to specify what you need, just call or fax our customer service department and we will be happy to help you. All Valves are (RoHS) 2015/863/EU Compliant.

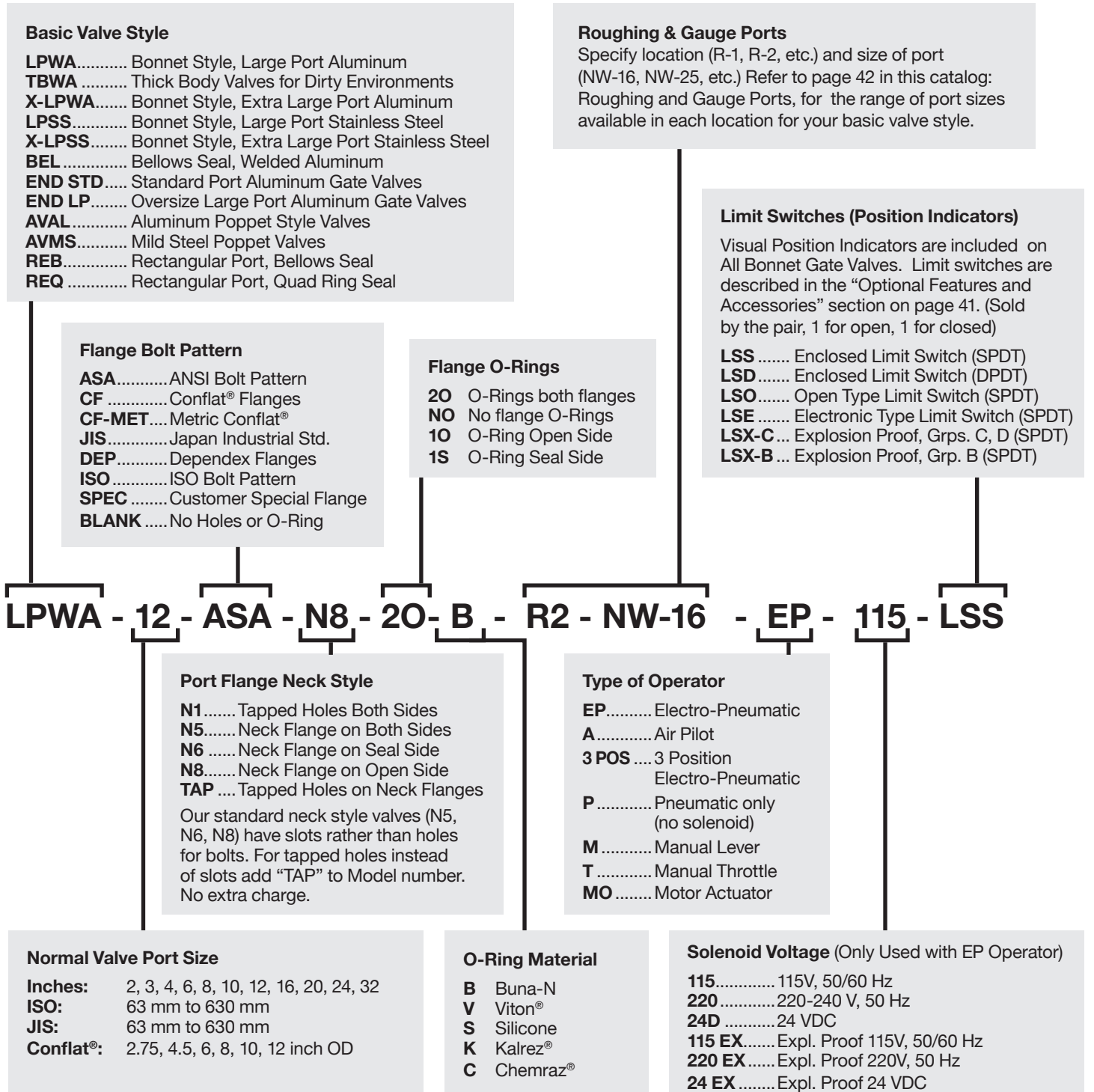

Call our toll free number (800) 426-9340, or (412) 261-7630 to place orders or for customer service. Our FAX number is (412) 261-7220. Address orders by mail to Vacuum Research Corporation, 100 Chapel Harbor Drive, #4, Pittsburgh, PA 15238 USA. Prices in this catalog are FOB factory. CIF or C&F prices available. Contact factory for pro forma invoice or price quotation. Terms are Net 30 days.



Throttlemaster™ is a registered trademark of Vacuum Research Corporation • Kalrez® and Viton® are registered trademarks of Dupont Corp. • Conflat® is a registered trademark of Varian Associates • Chemraz® is a registered trademark of Green, Tweed & Co. • SolidWorks logo art property of Dassault Systèmes.