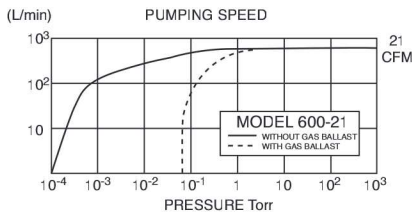
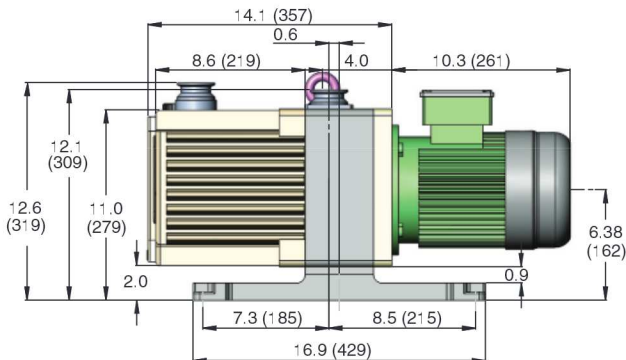



Photo shows Pump with optional inlet trap and exhaust mist eliminator installed. See pages 15 and 18 to order these accessories.



Pumping Speed @ 60 Hz	600 l/min, 21 CFM, 36 m <sup>3</sup> /hr.
Pumping Speed @ 50 Hz	500 l/min, 17.5 CFM, 30 m <sup>3</sup> /hr.
Ultimate Pressure Gas Ballast Closed	5x10 <sup>-4</sup> Torr, 6.7x10 <sup>-2</sup> Pa, .0006 mbar
Ultimate Pressure Gas Ballast Open	5x10 <sup>-2</sup> Torr, 6.7 Pascal, .06 mbar
Standard Motor, On/Off Switch, Circuit	230/380V, 1 phase, 50/60 Hz, 2 hp CE Mark, complies with
Optional Motors	See ordering information
Power Connection	Junction Box
Motor speed @ 60 Hz	1700 r.p.m.
Noise Level	54 dB
Water Vapor Tolerance	30 mbar, 22 Torr
Oil capacity	2300 cc; 2.4 Qt.
Weight Net: 117 lbs., 53 kg	Shipping: 133 lbs., 60 kg
Intake & exhaust type/diameter	NW-40 or 36 mm O.D. tube
Ambient operating temperature	7° to 40°C, 45° to 104°F



## Features

- Extremely Quiet • Anti Suck Back Design
- Satisfaction Guaranteed • Two Year Warranty
- Virtually Vibration Free • Motors for Any Voltage
- Complies with Machinery Directive 98/37/EC

## Applications

- Backing Turbo Pumps • Electron Microscopes
- Vacuum Ovens & Furnaces • Freeze Dryers
- Cluster Tool Load Locks • Sputter & Deposition Systems

## Typical Installation

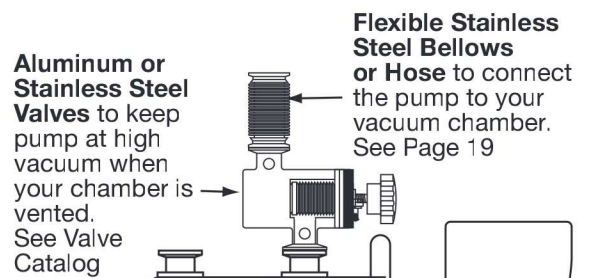

## Ordering Information

### MODEL 600-21 Vacuum Pump With Motor:

Note: Tolerance is ± 10% of nominal value for all voltages.

200V, 50 or 60 Hz, 3 phase, 1.5 kw (2 hp)  
p/n 600-CE-100/200-50/60.....\$4368

230 or 460V, 60 Hz, 3 phase, 1.5 kw (2 hp)  
Full load current 6.0 or 3.0 Amps  
p/n 600-CE-230-460-60.....\$4368

220 or 380V, 50/60 Hz, 3 phase, 1.5 kw (2 hp)  
Full load Current @ 50 Hz; 6.5 or 4 A @60 Hz; 6.0 or 3.6 A  
p/n 600-CE-380-50/60.....\$4368

208 or 380V, 50 Hz, 3 phase, 1.5 kw (2 hp)  
Full load current: 7.2 or 4.0 Amps  
p/n 600-CE-380-50.....\$4368

Pumps with motors for other voltages and single phase power also available. Please contact the factory for price and availability.

**Exhaust Mist Eliminators** ..... See Page 18  
Exhaust Filter Coalescing filter for exhaust mist elimination.  
99.97% removal efficiency of droplets down to 0.3 micron diameter.  
Model EX.FIL, NW-40, 21 cm

p/n RV810240.....\$408

**Fomblin:** For pumps filled with Fomblin PFPE fluid YL VAC 16/6  
add to p/n "Fomblin" and increase the price to.....\$6361