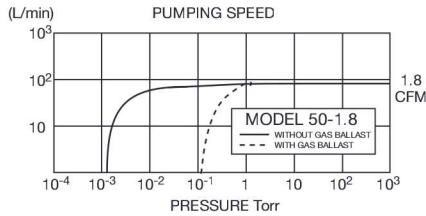
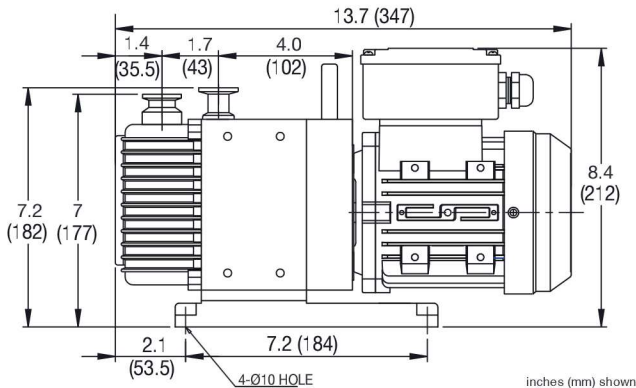



Photo shows Pump with optional inlet trap installed and exhaust mist eliminator. See pages 15 and 18 to order these accessories. Power on/off switch, resettable circuit breaker and line cord are standard on pumps shipped with single phase motors.



Pumping Speed @ 60 Hz	50 l/min, 1.8 CFM, 3 m <sup>3</sup> /hr.
Pumping Speed @ 50 Hz	42 l/min, 1.5 CFM, 2.5 m <sup>3</sup> /hr.
Ultimate Pressure Gas Ballast Closed	2x10 <sup>-3</sup> Torr, 0.27 Pa, 0.01 mbar
Ultimate Pressure Gas Ballast Open	2x10 <sup>-1</sup> Torr, 27 Pa, 0.27 mbar
Standard Motor, On/Off Switch, Circuit Breaker, & Thermal Protection	115/230V, 1 phase, 1/5 hp, 50/60 Hz
CE Mark, complies with	Machinery Directive 98/37/EC
Optional Motors	contact factory
Power Connection	6 ft. (2 m) 3 conductor cord
Motor speed @ 60 Hz	1680 r.p.m.
Noise Level	50 dB
Oil capacity	200 cc; 0.21 Qt.
Weight Net: 32 lbs., 14.4 kg	Shipping: 35 lbs., 16 kg
Intake & exhaust type/diameter	NW-16
Ambient operating temperature	7° to 40°C, 45° to 104°F



### Features

- Extremely Quiet • Anti Suck Back Design
- Satisfaction Guaranteed • Two Year Warranty
- Virtually Vibration Free • Motors for Any Voltage
- Complies with Machinery Directive 98/37/EC

### Applications

- Backing Turbo Pumps • Electron Microscopes
- Vacuum Ovens & Furnaces • Freeze Dryers
- Cluster Tool Load Locks • Sputter & Deposition Systems

### Typical Installation

Aluminum or Stainless Steel Valves to keep pump at high vacuum when your chamber is vented. See Valve Catalog

Flexible Stainless Steel Bellows or Hose to connect the pump to your vacuum chamber. See Page 19

Foreline Traps to minimize backstreaming of oil vapor into your system. See Page 15

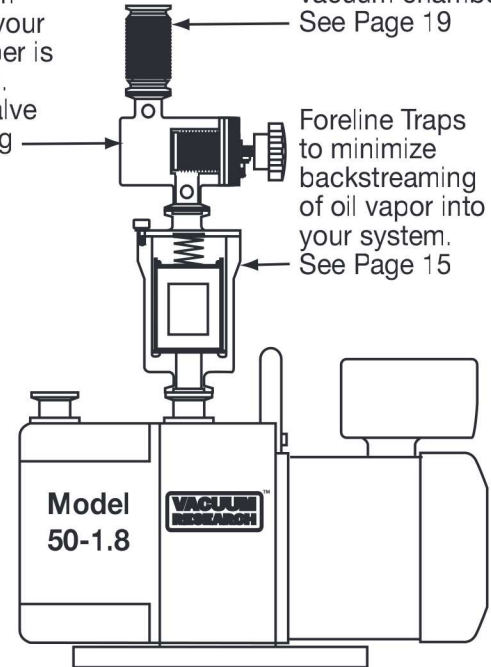

### Ordering Information

#### MODEL 50-1.8 Vacuum Pump With Motor:

Note: Tolerance is ± 10% of nominal value for all voltages.

115 or 230V, 50 or 60 Hz, 1 phase, 0.15 kw (1/5 hp)

Full load amps @ 60 Hz: 2.6 or 1.8 amps

Full load amps @ 50 Hz: 2.43 or 1.8 amps

p/n 50-115/230..... \$1966

Exhaust Mist Eliminators ..... See Page 18

Fomblin: For pumps filled with Fomblin PFPE fluid YL VAC 16/6 add to p/n "Fomblin" and increase the price to..... \$2595