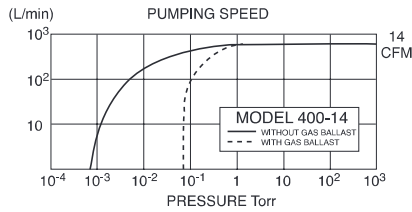
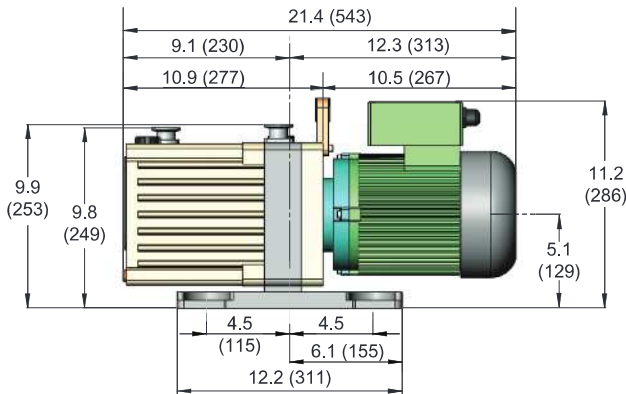



Photo shows Pump with optional inlet trap and exhaust mist eliminator installed. See pages 15 and 18 to order these accessories.



Pumping Speed @ 60 Hz	400 l/min, 14 CFM, 6 m <sup>3</sup> /hr.
Pumping Speed @ 50 Hz	333 l/min, 11.6 CFM, 5 m <sup>3</sup> /hr.
Ultimate Pressure Gas Ballast Closed	5x10 <sup>-4</sup> Torr, 6.7x10 <sup>-2</sup> Pa, .0006 mbar
Ultimate Pressure Gas Ballast Open	5x10 <sup>-2</sup> Torr, 6.7 Pascal, .06 mbar
Standard Motor, On/Off Switch, Circuit	115/230V, 1 phase, 50/60 Hz, 1 hp CE Mark, complies with
Optional Motors	See ordering information
Power Connection	Junction Box
Motor speed @ 60 Hz	1700 r.p.m.
Noise Level	52 dB
Water Vapor Tolerance	30 mbar, 22 Torr
Oil capacity	1500 cc; 1.5 Qt.
Weight Net: 70 lbs., 32 kg	Shipping: 75 lbs., 34 kg
Intake & exhaust type/diameter	NW-25 or 26 mm O.D. tube
Ambient operating temperature	7° to 40°C, 45° to 104°F



## Features

- Extremely Quiet • Anti Suck Back Design
- Satisfaction Guaranteed • Two Year Warranty
- Virtually Vibration Free • Motors for Any Voltage
- Complies with Machinery Directive 98/37/EC

## Applications

- Backing Turbo Pumps • Electron Microscopes
- Vacuum Ovens & Furnaces • Freeze Dryers
- Cluster Tool Load Locks • Sputter & Deposition Systems

## Typical Installation

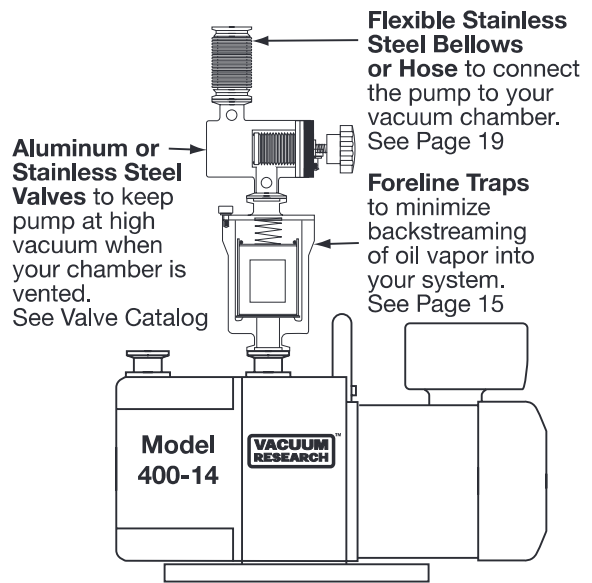

## Ordering Information

### MODEL 400-14 Vacuum Pump With Motor:

Note: Tolerance is ± 10% of nominal value for all voltages.

100 or 200V, 50 or 60 Hz, 1 phase, 0.75 kw (1 hp)  
**p/n 400-100/200-50/60 ..... \$2949**

115 or 230V, 50 or 60 Hz, 1 phase, 0.75 kw (1 hp)  
 Full load amps @ 50 Hz; 14.7 or 8.5 A @ 60 Hz; 13 or 7.5 A  
**p/n 400-115/230-50/60 ..... \$2949**

220 or 380V, 50 or 60 Hz, 3 phase, 0.75 kw (1 hp)  
 Full load current: @50 Hz; 3.6 or 2.1 A  
 @60 Hz; 3.1 or 1.8 A  
**p/n 400-OPT-380-50/60 ..... \$2949**

230 or 460V, 60 Hz, 3 phase, 0.75 kw (1 hp) Full load  
 current: 3.2 or 1.6 A  
**p/n 400-230/460-60 ..... \$2949**

**Exhaust Mist Eliminators ..... See Page 18**

**Fomblin:** For pumps filled with Fomblin PFPE fluid YL VAC 16/6  
 add to p/n "Fomblin" and increase the price to..... **\$4400**