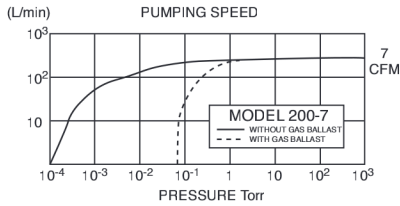
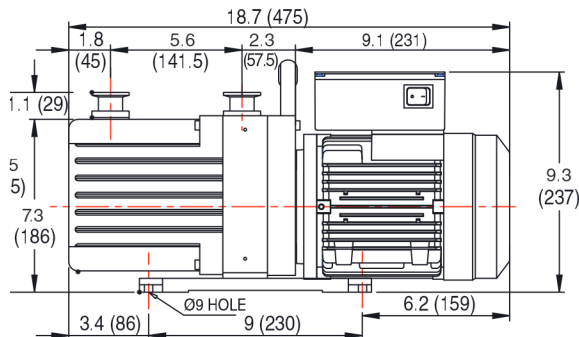



Photo shows Pump with optional inlet trap and exhaust mist eliminator installed. See pages 15 and 18 to order these accessories. Power on/off switch, resettable circuit breaker and line cord are standard on pumps shipped with single phase motors.



Pumping Speed @ 60 Hz	200 l/min, 7.0 CFM, 12 m ³ /hr.
Pumping Speed @ 50 Hz	166 l/min, 5.8 CFM, 10 m ³ /hr.
Ultimate Pressure Gas Ballast Closed	5x10 ⁻⁴ Torr, 6.7x10 ⁻² Pa, .0006 mbar
Ultimate Pressure Gas Ballast Open	5x10 ⁻² Torr, 6.7 Pascal, .06 mbar
Standard Motor, On/Off Switch, Circuit Breaker, & Thermal Protection	115/208-230V, 1 phase, 1/2 hp, 60 Hz (50Hz Avail)
CE Mark, complies with	Machinery Directive 98/37/EC
Optional Motors	See ordering information
Power Connection	6 ft. (2 m) 3 conductor cord
Motor speed @ 60 Hz	1700 r.p.m.
Noise Level	50 dB
Water Vapor Tolerance	25 mbar, 19 Torr
Oil capacity	600 cc; 0.63 Qt.
Weight Net: 50 lbs., 23 kg	Shipping: 54 lbs., 24 kg
Intake & exhaust type/diameter	NW-25 standard (NW-16 or 26 mm O.D. Tube optional)
Ambient operating temperature	7° to 40°C, 45° to 104°F



Features

- Extremely Quiet • Anti Suck Back Design
- Satisfaction Guaranteed • Two Year Warranty
- Virtually Vibration Free • Motors for Any Voltage
- Complies with Machinery Directive 98/37/EC

Applications

- Backing Turbo Pumps • Electron Microscopes
- Vacuum Ovens & Furnaces • Freeze Dryers
- Cluster Tool Load Locks • Sputter & Deposition Systems

Typical Installation

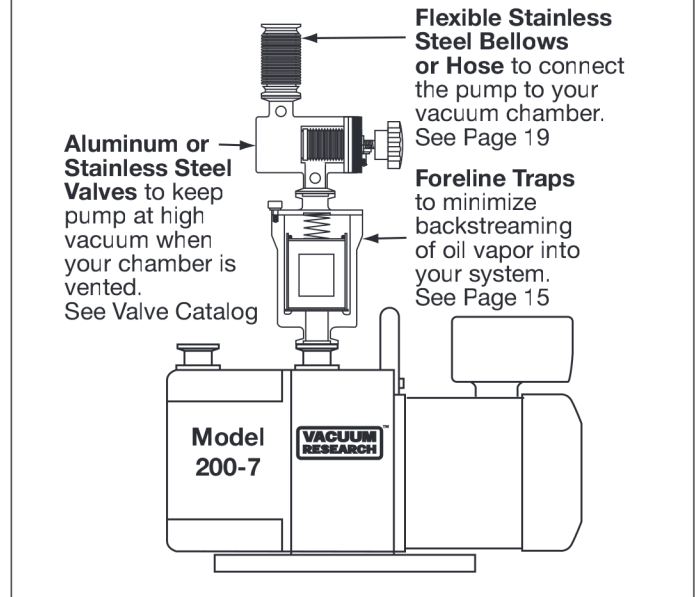

Ordering Information

MODEL 200-7 Vacuum Pump With Motor:

Note: Tolerance is ± 10% of nominal value for all voltages.

100 or 200V, 50 or 60 Hz, 1 phase, 0.4 kw (1/2 hp)
p/n 200-100/200-50/60 or 200-100/200-50/60-NW16 \$2162

115 or 208 to 230V, 60 Hz, 1 phase, 0.4 kw (1/2 hp)
 Full load amps: 8.5 or 4.5 to 4.0 amps
p/n 200-115/230-60 or 200-115/230-60-NW16 \$2162

115 or 230V, 50 or 60 Hz, 1 phase, 0.4 kw (1/2 hp)
 Full load amps @ 50 Hz; 8.8 or 4.4 A @ 60 Hz; 7.2 or 3.6 A
p/n 200-115/230-50/60 or 200-115/230-50/60-NW16 \$2162

230 or 380V, 50 or 60 Hz, 3 phase, 0.4 kw (1/2 hp)
 Full load current: 1.82 or 1.3 A
p/n 200-OPT-380-50/60 or 200-OPT-380-50/60-NW16 \$2162

230 or 460V, 60 Hz, 3 phase, 0.4 kw (1/2 hp) Full load current: 1.8 or 0.9 A
p/n 200-230-/460-60 or 200-230-/460-60-NW16 \$2162

Exhaust Mist Eliminators See Page 18

Optional NW-16 Inlet & Outlet \$57

Fomblin: For pumps filled with Fomblin PFPE fluid YL VAC 16/6 add to p/n "Fomblin" and increase the price to..... **\$2831**