



Model 1800-64 has NW-40 flanges for inlet and exhaust ports

Features

- Extremely Quiet • Anti Suck Back Design
- Satisfaction Guaranteed • Two Year Warranty
- Virtually Vibration Free • Motors for Any Voltage
- Complies with Machinery Directive 98/37/EC

Applications

- Plasma Systems • Electron Microscopes
- Vacuum Ovens & Furnaces • Freeze Dryers
- Cluster Tool Load Locks • Backing Turbo Pumps
- Sputter & Deposition Systems

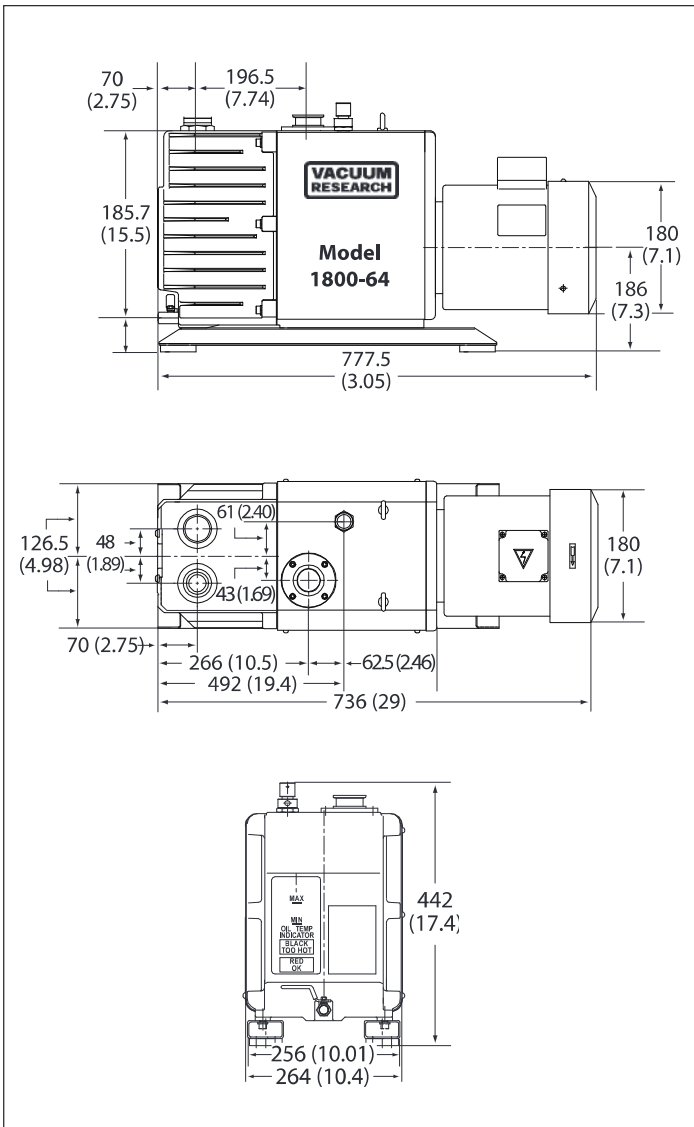
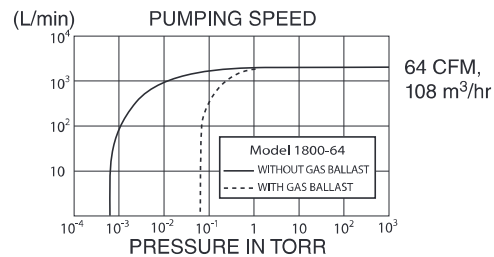

Pumping Speed @ 60 Hz	1800 l/min, 64 CFM, 108 m ³ /hr.
Ultimate Pressure Gas Ballast Closed	5x10 ⁻⁴ Torr, 6.7x10 ⁻² Pa, .0006 mbar
Ultimate Pressure Gas Ballast Open	5x10 ⁻² Torr, 6.7 Pascal, .06 mbar
Standard Motor, On/Off Switch, Circuit	220/380V, 3 phase, 5 hp, 50/60 Hz
CE Mark, complies with	Machinery Directive 98/37/EC
Optional Motors	See ordering information
Power Connection	Junction Box
Motor speed @ 60 Hz	1700 r.p.m.
Noise Level	57 dB
Water Vapor Tolerance	40 mbar, 30 Torr
Oil capacity	6200 cc; 6.5 Qt.
Lifting Lugs (on center of gravity)	2 Rings, 3/4" (19 mm) ID, M8 Thread
Holes in Base for Lag Bolts	4 Holes, 0.5" (12 mm) 22"x7" (550x178)
Weight Net: 265 lbs., 120 kg	Shipping: 410 lbs., 186 kg
Intake & exhaust type/diameter	NW-40 standard (Contact factory for more options)
Inlet Screen	Cone Shaped Removable Screen
Ambient operating temperature	7° to 40°C, 45° to 104°F

Ordering Information

MODEL 1800-35 Vacuum Pump With Motor:

Note: Tolerance is ± 10% of nominal value for all voltages.

- 200V, 50/60 Hz, 3 phase, 3.7 kw (5 hp)
p/n 1800-CE-200 50/60.....\$9566
- 220/380V, 50/60 Hz, 3 phase, 3.7 kw (5 hp)
p/n 1800-CE-380 50/60.....\$9566
- 230/460V, 50/60 Hz, 3 phase, 3.7 kw (5 hp)
p/n 1800-CE-230-460 50/60.....\$9566

Fomblin: For pumps filled with Fomblin PFPE fluid YL VAC 16/6 add to p/n "**Fomblin**" and increase the price to.....**\$13,569**