

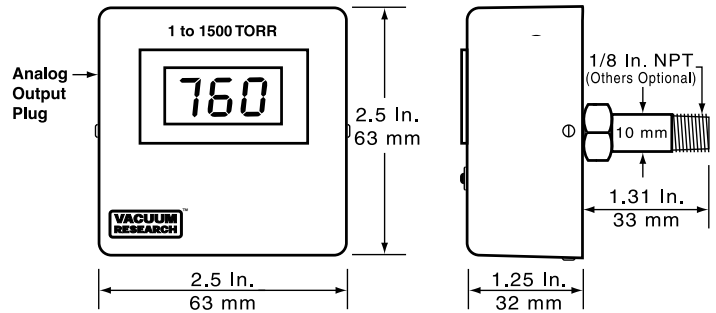

Integral Sensor Gauges, Pirani & Diaphragm, AC Line Power



Pirani Gauge 1 to 1200 milliTorr

These compact vacuum instruments offer the precision and high resolution of a digital display at the same price as analog instruments. Our extremely rugged sensor is constructed with a solid, inert, noble metal that maintains its calibration over long periods. Because no gold is used, these gauges are compatible with both mercury and oil pumps. The low 125 °C operating temperatures in our Pirani type gauge tube (half that of thermopile gauges), enhances stability as does the unique temperature compensation network.

Specifications

Pressure Range: 1 to 1200 milliTorr (.001 to 1.500 mbar optional)

Calibration: Air or Nitrogen.

Accuracy: Better than 5% of value or ± 3 mTorr, whichever is larger.

Response Time: 0.3 second time constant.

Analog Output: 0 to 1.2 Volts into 2000 Ohm load or higher. 2 pin connector included.

Vacuum Connection: is 1/8 NPT male thread or fits into quick connects sized for 1/8 inch pipe (0.405" dia.). NW, VCR and Mini Conflat® available. Refer to ordering information below.

Materials: Wetted parts 300 series stainless steel and platinum alloy.

Power: Gauge operates from 15 to 24 VDC less than 200 mA. An external wall mount supply is included with each instrument. 90 to 240V. 50/60 Hz input and 15 VDC output.

Temperature Effects: Changes in ambient temperature between 0 °C and 50 °C change the reading less than 0.2 mT per °C at 50 mT; less than 4 mT per °C at 900 mT.

Operating Temperature: 0 to 50 °C (32 to 120 °F).

Maximum Positive Pressure: 50 PSIG.

Dimensions: 2.5 x 2.5 x 1.25 inches (63 x 63 x 32 mm).

Mounting: Sensor and display in one integrated package. Mount directly on your vacuum system.

Gauge Tube Cables: None required.

Weight: Approximately 6 ounces (170 grams.)

Ordering Information

Buy Now! Go to www.vacuumresearch.com to order online

Integral Sensor Pirani Gauge

1 to 1200 milliTorr Digital Display with 0 to 1.2 VDC linear output. Sensor and display integrated into one package.

Vacuum Connection 1/8 in. NPT, P/N: 902034 \$250.
Vacuum Connection NW-16, P/N: 902022 \$288.
Vacuum Connection NW-25, P/N: 902031 \$288.
Vacuum Connection 1.33 cf, P/N: 902023 \$288.
Vacuum Connection 1/2 in. OD Tube, P/N: 902024 \$288.

Rebuild or Repair Integral Sensor Pirani Gauge

Use original P/N plus "RBLD" suffix, e.g.: 902034-RBLD. Return old gauge to factory or local distributor with purchase order \$87.

Diaphragm Manometer 1 to 1500 Torr

The Vacuum Research Integral Sensor Diaphragm Manometer uses a silicon or 316L SS diaphragm that can measure liquid or gas pressure as well as vacuum. Response time is less than 400 milliseconds for full scale and instruments are available with a variety of flanges including 15 mm, VCR, and NW-16. These instruments offer the high resolution of a digital display plus linear outputs for PLCs or data acquisition systems.

Specifications

Pressure Range: 1 to 1500 Torr, (1 - 2000 mbar & 0.1 - 200 kPa available)

Calibration: Any gas, liquid or vacuum compatible with sensor materials.

Accuracy: 1% of reading or 2 Torr.

Response Time: Less than 400 msec. for response to a step change.

Linearity: ± 0.15% Full Scale. **Sensitivity:** ± 1 Torr.

Analog Output: 0 to 1.500 V into 2000 Ohm load. Connector included.

Vacuum Connection: Refer to ordering information below.

Materials: in contact with process are 316, 304 SS, or silicone & silicon.

Sensor Internal Volume: Approximately 0.5 ml.

Line Regulation: ± 20% change in line voltage produces less than 1 % change in reading. From 10 - 240V.

Line Power: 90 to 240 VAC, 50/60 Hz. **Wattage:** Less than 1 Watt.

Operating Temperature: 0 to 50 °C (32 to 120 °F).

Temperature Effects: When changes occur in ambient temperature between 0° and 50 °C, reading will change no more than ±0.02% per °C.

Dimensions: 2.5 x 2.5 x 1.25 inches (63 x 63 x 32 mm).

Mounting: Sensor and display mount directly on your vacuum system.

Transducer Cables: None required.

Weight: Approximately 6 ounces (170 grams.)

Ordering Information, Silicon Diaphragm

Integral Sensor Diaphragm Gauge, 1 to 1500 Torr Digital Display with 0 to 1.5 VDC linear output. Sensor and display integrated into one package.	
Vacuum Connection 1/8 in. NPT, P/N: 902158 \$300.
Vacuum Connection NW-16, P/N: 902163 \$339.
Vacuum Connection 1.33 cf, P/N: 902164 \$339.
Vacuum Connection 1/2 in. OD Tube, P/N: 902165 \$339.

Ordering Information, 316L SS Diaphragm

1/8 in. NPT, P/N: 902324 \$445.	1.33 CF, P/N: 902325 \$483.
NW-16, P/N: 902321 \$483.	2.75 CF, P/N: 902326 \$483.
NW-25, P/N: 902323 \$483.	VCR-8 FEM, P/N: 902327 \$503.
1/2 in. O.D., P/N: 902328 \$445.	VCR-4 FEM, P/N: 902329 \$503.
15 mm O.D., P/N: 902322 \$483.		

Rebuild Integral Sensor Diaphragm Gauge

Use original P/N plus "RBLD" suffix. Return old gauge to vendor. Silicon Diaphragm \$131. 316L SS Diaphragm \$304.